

# Blighter<sup>®</sup> BRTS (Blighter Radar Tilting System)

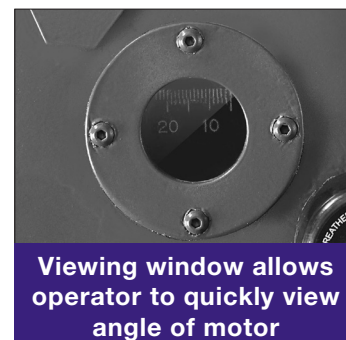

Viewing window allows operator to quickly view angle of motor

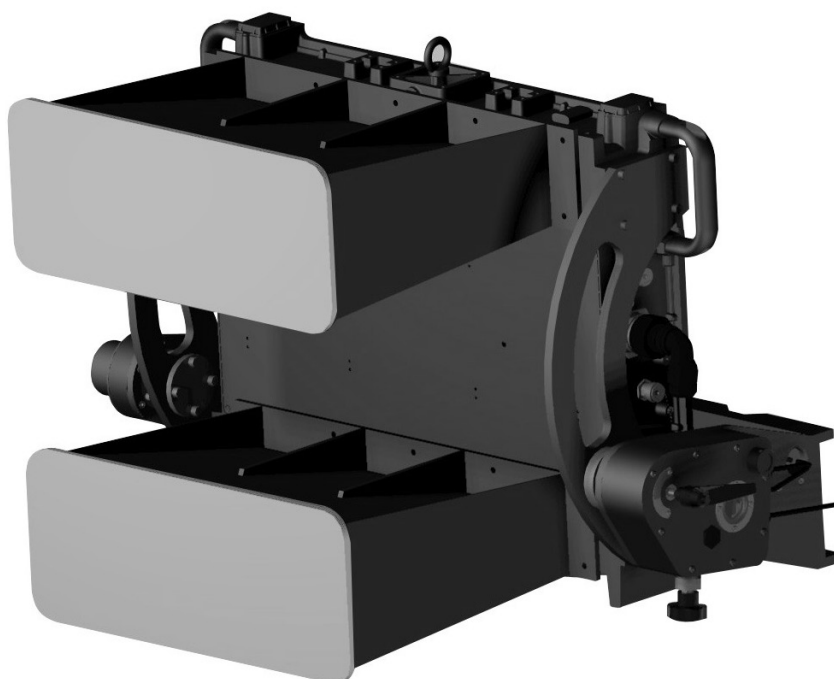

Set point adjustment

- Payload capacity of up to 40kg (per unit)
- Potentiometer position feedback
- Fitted with manual set point adjustment lever
- Viewing window for motor angle scale
- Fitted with an overload clutch
- Daisy chain option for dual radar units
- Fitted manual motor adjustment for setup
- Environmental specification meets MIL-STD-810G and 461E



Manual motor adjustment

Designed principally for the Blighter A400 series radars, the Blighter Radar Tilting System (BRTS) provides accurate control of the elevation tilt position of individual Blighter radar units. The BRTS allows the Blighter radar to maintain elevation control in situations where it needs to detect and then track flying objects, especially UAVs, at various altitudes and also where terrain variation requires the radar to be tilted in order to maximise ground coverage.

The BRTS includes a motor driven tilt angle range of  $-20^{\circ}$  to  $+20^{\circ}$  and a manual set-point tilt angle setting of between  $-20^{\circ}$  to  $+10^{\circ}$ . This provides a total tilt adjustment range of  $-40^{\circ}$  to  $+30^{\circ}$ .

The BRTS is designed specifically for the Blighter product range and offers high reliability in extreme conditions. It provides precise control and feedback

of radar position for full integration into the BlighterView HMI. The tilt adjustment speed of the BRTS is carefully controlled to ensure that its movement does not affect the ultra-slow movement detection capability of the Blighter radar.

BRTS includes features to simplify installation including a manual motor adjustment wheel, and a viewing window with tilt angle graticule. The position feedback mechanism on each unit measures absolute position allowing the BRTS to be rapidly installed and adjusted to a pre-set value without additional tools.

The BRTS is available for single (A402) and dual radar units (A422) with the second unit being daisy-chained to the first to provide a single serial interface to the Blighter radar system.

# Operation

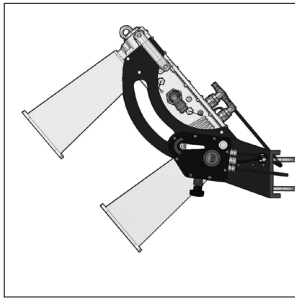

BRTS Look Down: -40°

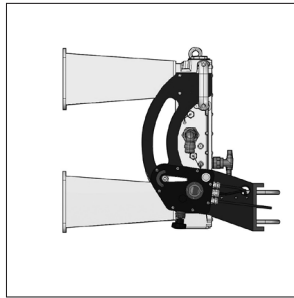

BRTS Horizontal: 0°

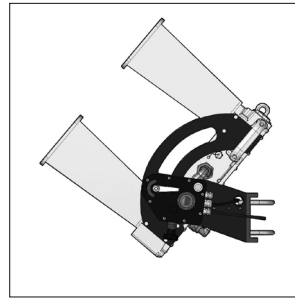

BRTS Look Up: +30°

# Specification

## General

- Unit weight: 12 kg (26.5 lbs)
- Payload weight: up to 40 kg (88.2 lbs)

## Mechanical

- Manual mechanical angle set point: -20° to +10°
- Motor driven angular range: +/- 20°
- Combined maximum angular range: -40° to +30°

## Performance (gearbox options for each axis)

- Maximum speed: 0.8° per second (Note: dependent on wind force and payload weight)
- Total travel time over 40° range: 50 s
- Maximum output torque: 80 Nm

## Electrical

- Power supply: 24 V (DC)
- Communications: RS-422

## Environmental

- Operating temperature: -32° C to +50° C (-25° F to +122° F)

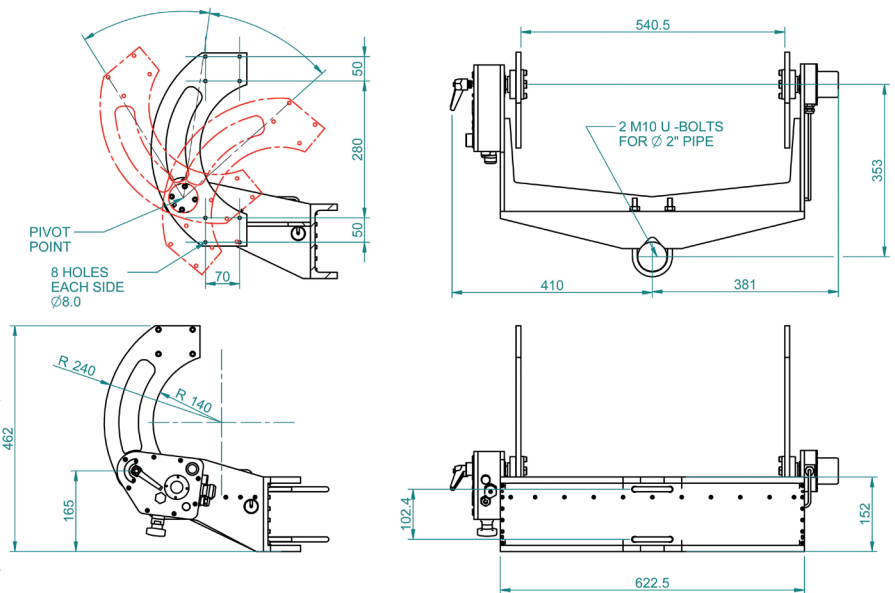

BSS-1604 ©2019 Blighter Surveillance Systems Ltd

Errors and omissions excepted. Blighter Surveillance Systems Ltd reserves the right to modify specifications without notice. Blighter radars are protected by a number of international patents. The Blighter name is an international registered trademark.

**Blighter** Surveillance Systems Ltd

Iceni House  
London Road  
Great Chesterford  
Saffron Walden  
CB10 1NY  
United Kingdom

[www.blighter.com](http://www.blighter.com)  
[hello@blighter.com](mailto:hello@blighter.com)

Tel: +44 1223 491122  
Fax: +44 1223 491123